



Maintenance is a Breeze

Centrisys Screw Press SP20

With four divided screens, the Centrisys SP20 is simple to operate, maintain and clean. The four screen baskets and horizontal design allow for most maintenance to be completed without removing the screw shaft. There is no need to pull the auger out; simply open the maintenance cover to clean.

The SP20 combines a longer screen design and dual filtrate zones to create dryer cake solids, cleaner centrate and maximum water drainage. Two filtrate zones allow for the separate collection of clean and dirty centrate. The longer screen design increases retention time by using the entire length of the screw for dewatering.

The SP20 has two moving screw sprayer systems, located in each filtrate zone. Because each sprayer system can be controlled separately, water consumption is reduced. A Pneumatic regulator adjustment in the pressure cone discharge increases the time under pressure leading to a higher discharge and maximum dry cake solids.

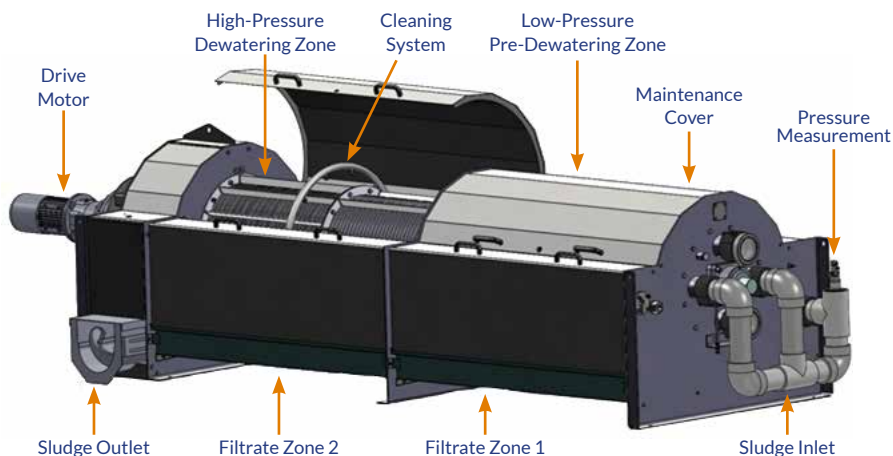

Advantages

- Fully enclosed design for odor and moisture containment
- Four-parted screen baskets with accessibility to the top half shell for simple service and maintenance
- Optimized footprint due to sectioning of the screens
- Energy efficient with a small gearbox or hydraulic motor
- Automated operation with easy start-up and shut-down
- Horizontal installation allows for two separate filtrate outlets
- Greater L/D ratio, which results in a longer retention time with improved dewatering results
- Minimum wear and vibration due to the low speed of the compacting screw <math>< 5 \text{ rpm}</math>
- Stainless steel covered unit
- Integrated flocculation reactor to create more efficient contact time





	SP20
L x W x H in (m)	208.7 x 55.2 x 47.2 (5.3 x 1.4 x 1.2)
Weight lbs (kgs)	5,000 (2,268)
Sludge Throughput gpm (m ³ /h)	9-66 (2-15)
DS Throughput lb/h (kg/h)	440 (200)
Inlet Solids Concentration %	0.5-5
Outlet Solids Concentration %	20-30*

*Depends on sludge conditions.

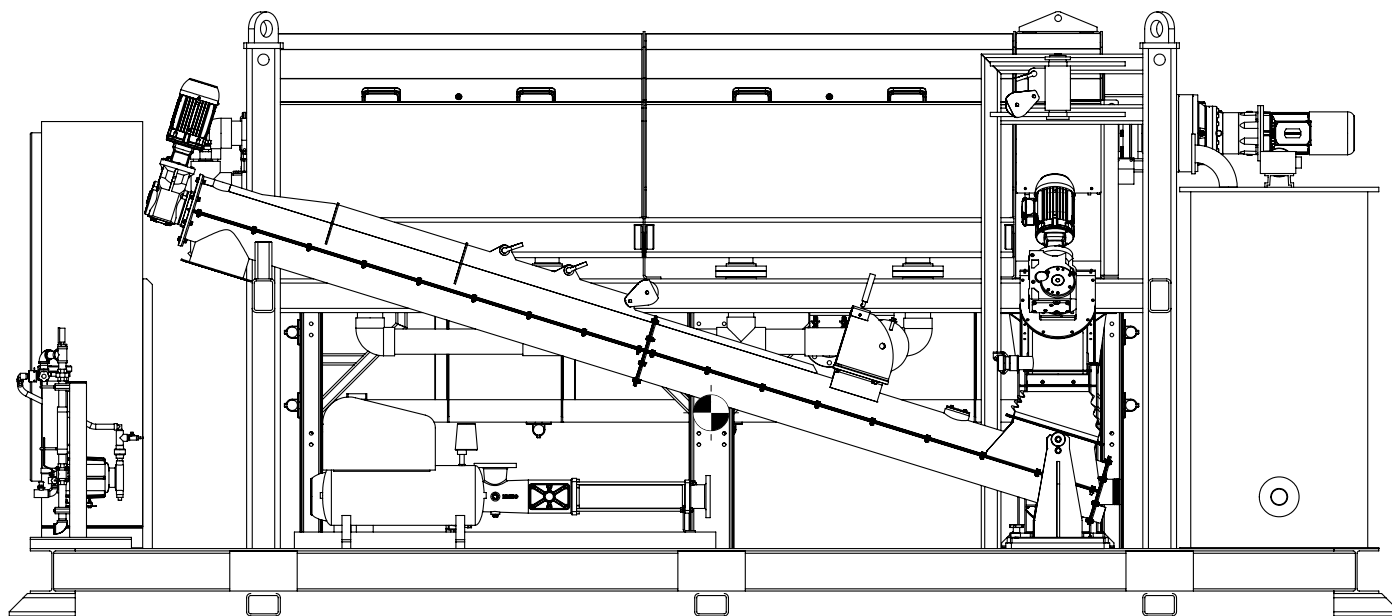

Questions about Centrisys technologies?

Corporate 9586 58th Place | Kenosha, WI 53144 **P** +1 (262) 654-6006 **E** info@centrisys.com
Global Presence North America | South America | Europe | Middle East | China



ISO 9001:2015

POSP2017V1EN